

# UNI-FLO SINGLE DISK WAFER SWING CHECK VALVE FIG 302



## DIMENSIONS

DN (mm)	A BS, TD & E	B	C	D
50	96	44.5	33.3	28.6
65	109	47.6	42.9	30.2
80	128	50.8	52.4	55.6
100	160	57.2	76.2	74.6
125	191	63.5	95.3	95.3
150	212.6	69.9	163.5	155.6
200	270	73	120.7	114.3
250	333	79.4	193.7	187.3
300	380.8	85.7	241.3	222.3
350	447.7	108	266.7	288.6
400	498.5	108	317.5	247.7

## DESCRIPTION

Design and Manufacture	EN12334
Pressure Rating (Mpa)	PN16
Sealing Test Pressure (Mpa)	1.76MPa
Strength Test Pressure (Mpa)	2.4MPa
Suitable temperature (°C)	NBR: -10°C ~ +80°C EPDM: -10°C ~ +120°C VITON: -10°C ~ +150°C
Suitable Medium	fresh water, sea water, waste water, foodstuff all oils, all acids & alkaline liquid, etc
Eye screw	eye screw available from 125mm and above

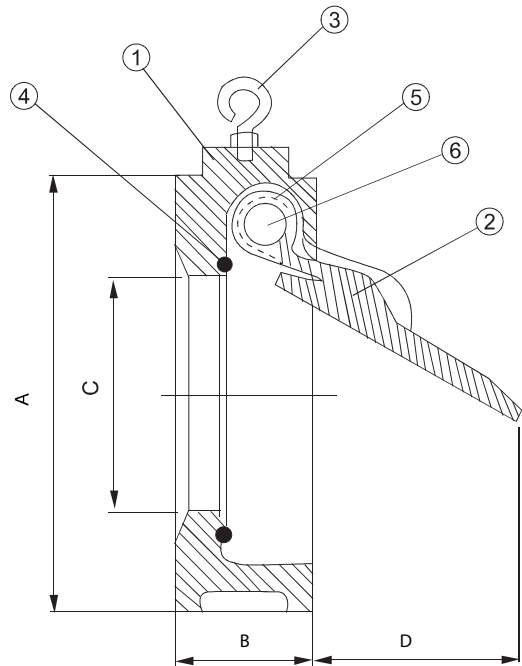

## MATERIALS LIST

PART	MATERIAL	STANDARD
1 Body	Cast Iron	GG20/25
2 Disc	Stainless Steel	304 - 316 Opt
3 Eye Screw	Carbon Steel	
4 Seat Ring	VITON	
5 Spring	Stainless Steel	304 - 316 Opt
6 Shaft	Stainless Steel	2Cr13