

UNI-FLO DOUBLE DOOR WAFER CHECK VALVE

PN16 FIG 301

DESCRIPTION

The Uni-Flo Double Door Check Valve compact wafer design features non-slam spring-assisted closure to prevent back flow of medium in pipelines. Tight closure is obtained by utilising a soft seat. Pressure rating is PN16.



DIMENSIONS

DN (mm)	D	L	R
50	96	43	30
65	109	46	36
80	128	64	43
100	160	64	53
125	191	70	66
150	218	76	79
200	274	89	104
250	328	114	127
300	378	114	147
350	438	127	172
400	489	140	197
450	532	152	218
500	585	152	241
600	690	178	295

MATERIALS LIST

PART	MATERIAL
Body	Epoxy powder coated Cast Iron.
Disk	Chrome Plated Ductile Iron or Stainless Steel (304SS)
Seat	EPDM
Shaft	Stainless Steel (304SS)
Spring	Stainless Steel

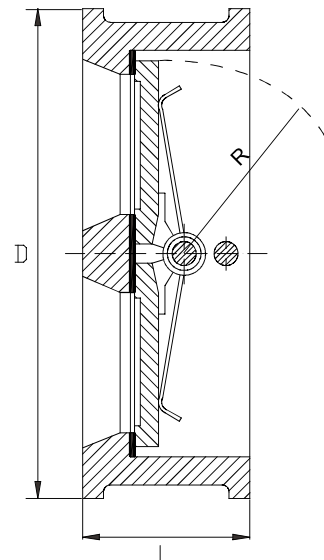

UNI-FLO FIG. 301

OPTIMUM INSTALLATION

In a horizontal pipe, the check valve must always be installed with its hinge in the vertical position as illustrated.

The minimum recommended distance for a check valve installed upstream from a bend, tee, pump, valve or any pipeline component that can cause a disruption in flow is six times the diameter of the pipeline.

When a check valve is installed downstream of a disrupting component, the minimum recommended distance is twice the diameter of the pipeline.

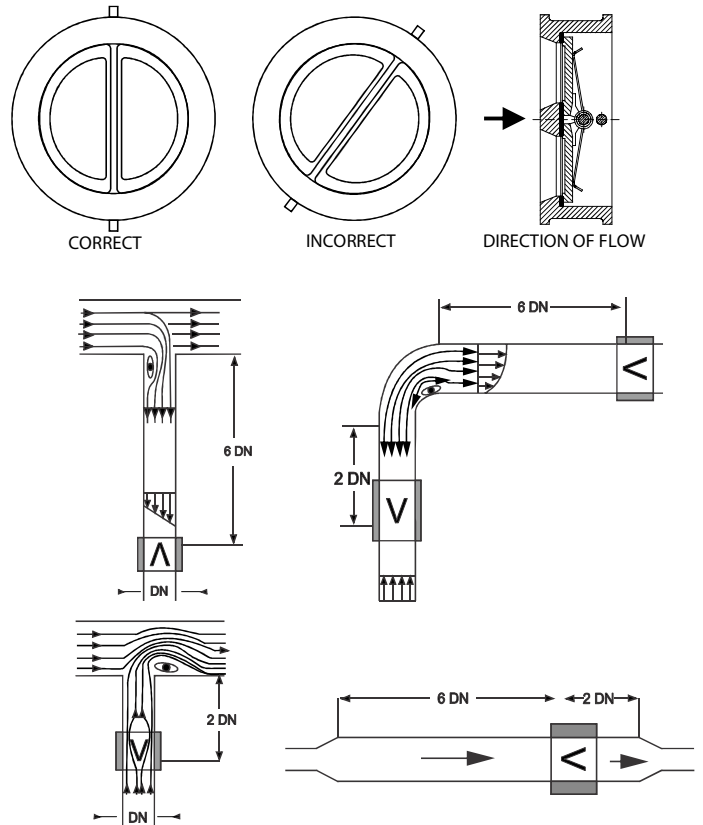

HYDRAULIC CHARACTERISTICS

DN	FLOW COEFFICIENT FULL OPEN POSITION	DN	FLOW COEFFICIENT FULL OPEN POSITION
mm	Kv	mm	Kv
50	75	250	2308
65	112	300	3863
80	141	350	4616
100	240	400	6020
125	450	450	8529
150	750	500	10034
200	1300	600	12543